

101

C O P E N H A G E N



Snake Wall Lamp - Burned Black

Designed by

Kristian Sofus Hansen &
Tommy Hyldahl

Snake Wall Lamp - Burned Black

Product Description

The Snake Wall Lamp is a study in movement, an exploration of how light can flow like a living line through space. Inspired by the silent grace of a snake in motion, the design transforms solid metal into a gesture of softness, where curves and bends become expressions of quiet energy.

The form seems to move even when still. Slender pipes bend and twist with sculptural precision, guiding the eye toward a refined conic shade that emits a warm, inviting glow. Light diffuses gently, creating a subtle contrast between illumination and the lamp's architectural silhouette.

In Burned Black, the design gains depth and intensity. The matte charcoal-black surface carries a warm red undertone, revealed softly as light moves across it. Bold yet understated, this finish enhances the graphic quality of the form while maintaining a calm and refined presence.

The Snake Wall Lamp in Burned Black works beautifully in modern interiors where contrast and structure are key. Use it as a dramatic accent in corridors, reading corners, or beside the bed, where its dark finish creates a strong visual statement while delivering soft, ambient light.

Designer Description

Tommy Hyldahl and Kristian Sofus Hansen intertwine their distinct sensibilities to create designs where storytelling, materiality, and timeless form meet in quiet harmony.

With a background in fashion, Tommy brings an intuitive eye for trends, colors, and textures. His process is one of layering histories, blending details and references from past design periods and reimagining them into something fresh and contemporary. Each collection unfolds as a narrative, evolving from concept to creation, with every element contributing to a greater story.

Kristian, who has lived and studied in Japan, seeks to unite Japanese aesthetics with Danish design, creating a characteristic twist on simplicity itself. His work is defined by the search for subtle, original details that elevate each piece with a unique signature. Drawing inspiration from art and sculpture, his creative process unfolds in new and exciting ways, always striving to craft designs that are both functional and timeless.

Together, they craft design that transcends time, poetic yet practical, expressive yet enduring.

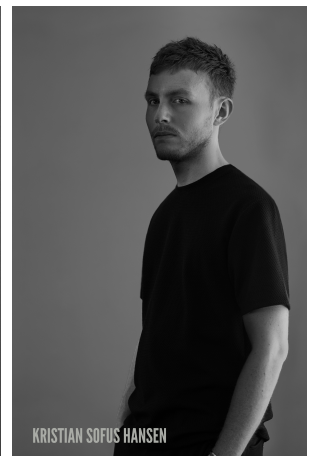

Snake Wall Lamp - Burned Black

Main

SKU	262022	Product Family	Snake
Product name	Snake Wall Lamp - Burned Black	Color	Burned Black
Product Type	Wall Lamp	Size	Regular
		Unit	Piece

Logistics

EAN number	4251501415077	Package - CBM	0.005
Package height in cm	44.00	Package - Weight KG	4.500
Package width in cm	10.00	Tariff Code No	9405199090
Package length in cm	12.00	Country of origin	China
		Quantity of Inner Boxes	4

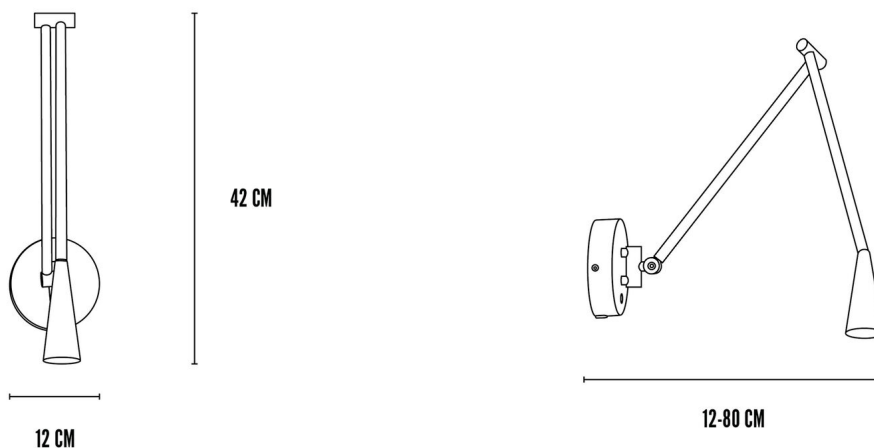

Snake Wall Lamp - Burned Black

Product

Materials	Hand Brushed Plated Aluminium	Light Source	G9
Item Height in cm	42	Lighting Certification	CE-Certificate
Item width in cm	12	Cable Length	None
Item length in cm	12	Max Watt (W)	8
Net weight in kg	3	Socket	G9 x 1 - 230V
Ceiling Cup Size	N/A	IP Rating	20

Led

Color Temperature		Lumen (lm)	N/A
Energy Class	N/A	Illuminant Lifetime (h)	N/A
EPREL No.	N/A	Driver Type	N/A

Snake Wall Lamp - Burned Black

Family Description Text

The Snake Collection is a study in movement, an exploration of how light can flow like a living line through space. Inspired by the silent grace of a snake in motion, each piece transforms solid metal into a gesture of softness, where curves and bends become expressions of quiet energy.

The form seems to move even when still. Slender pipes bend and twist with sculptural precision, leading the eye toward refined conic shades that emit a warm, inviting glow. The light diffuses gently, creating an atmosphere that contrasts beautifully with the cool tactility of metal. This balance between hardness and warmth, structure and fluidity, defines the collection's calm yet expressive presence.

Designed to shape both space and mood, the Snake Collection invites light to become part of the architecture, not merely an object but a motion captured in form. Each curve tells a story of transformation, where material becomes movement and illumination becomes emotion. The result is a timeless expression of modern elegance, simple, poised, and quietly alive.

Color Description

Burned Black is a deep, charcoal-black tone enriched with a subtle warm red undercurrent. Its matte powder-coated surface delivers a smooth, consistent appearance, while gentle tonal shifts emerge as light moves across it. Bold yet quietly warm, Burned Black brings depth, richness, and a refined architectural presence to any palette.

Snake Wall Lamp - Burned Black

Maintenance Guide Description

Our lights crafted in powder coated aluminium are designed to offer lasting durability and a refined, contemporary finish. To preserve their beauty and ensure long-lasting performance, regular and gentle care is essential. The powder coated aluminium should be dusted regularly with a soft, dry microfiber cloth, and for deeper cleaning, a slightly damp cloth with mild, pH-neutral soap may be used, wiping gently to avoid compromising the coating. Avoid abrasive pads, acidic or alkaline solutions, solvents, or metal polishes, as these can dull, scratch, or damage the surface. Always switch off and unplug the light before cleaning, and prevent exposure to excessive humidity or direct water contact to protect both the coating and the internal electrical components. With simple, consistent care, the powder coated aluminium will maintain its elegant finish, ensuring your light remains beautiful and timeless for years to come.

Materials Description

Hand-brushed plated aluminium reflects the meeting of craftsmanship and time. Each piece is plated and then brushed by hand, creating subtle variations in tone and texture that make every object unique. A final matte coating softens the sheen into a silky finish, enhancing the surface with quiet movement and depth.